



# WME-A

## Signal Tower



WME-A



- LED
- 2 Alarm Sounds (FB Type)
- 90dB at 1m
- IP65 (FB Type:IP54)
- W70 D80
- NPN/PNP Open-collector

## Exclusive wall-mount design saves space and enhances its integral appearance.

### Interchangeable LED Modules

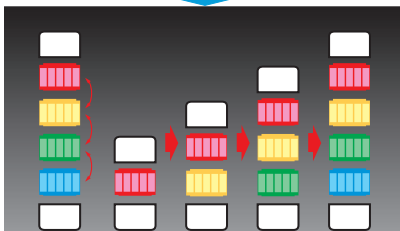

LED Tiers are changeable, even after installation.

**Note:** Shafts that match the number of tiers also has to be purchased.

### FEATURES

- Built-in audible alarm (FB type)
- Volume output of up to 90dB (at 1m).
- Easy vertical or horizontal installation when used with mounting brackets.
- Interchangeable Modules need no re-wiring, even after installation.
- Install as an option with a compatible household switch box (JISC 8336 with 82.5m pitch).
- Main body is made of ABS resin.
- Lens is made with superior impact and heat resistant polycarbonate resin for superior durability and illumination.
- Compatible for use with NPN or PNP controlled inputs (24V DC type ONLY).
- Available Colors are in Red, Amber, Green, Blue, and Clear/White.
- Has the CE mark and conforms to the requirements for the EC directive.
- Is a UL Recognized Component (File No. E215660).

### AVAILABLE BY SPECIAL ORDER

- 1 Tier Type
- Individual module control for single color

### 5 "Super Bright" LED Colors to choose from!

Red



Amber



Green



Blue



Clear/White



### Exclusively New LED Lighting Design

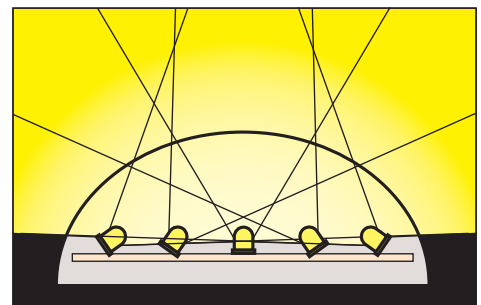

Patlite has created a revolutionary patented lighting design in which multiple LEDs project light across a broad peripheral area, ensuring equal intensity at the sides as well as the front. This design, with its side-projection technology, is a unique achievement in signal light design.

## How to Order

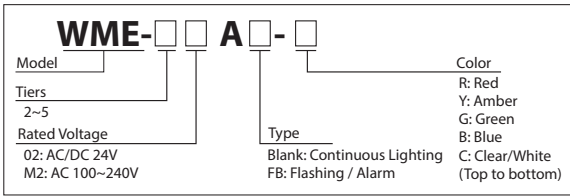

## Specifications

Stack Number	Model	Rated Voltage	Power Consumption	Mass
2 Tiers	WME-202A	AC/DC 24V	2.7W	390g
	WME-2M2A	AC 100 - 240V	4.6W	460g
3 Tiers	WME-302A	AC/DC 24V	3.3W	470g
	WME-3M2A	AC 100 - 240V	6.0W	540kg
4 Tiers	WME-402A	AC/DC 24V	4.4W	550g
	WME-4M2A	AC 100 - 240V	8.0W	620g
5 Tiers	WME-502A	AC/DC 24V	5.5W	630g
	WME-5M2A	AC 100 - 240V	10.0W	700g

Signal Line voltage and current per LED Module

Model	Rated Voltage	Signal Line Voltage	LED		Alarm	
			Signal Line Current		Signal Line Current	Inrush Current
			R, Y	G, B, C		
WME-A	AC/DC 24V	AC/DC 24V	35mA	50mA	40mA	250mA
	AC 100V - 240V	DC 24V				

## Dimensions (Unit: mm)

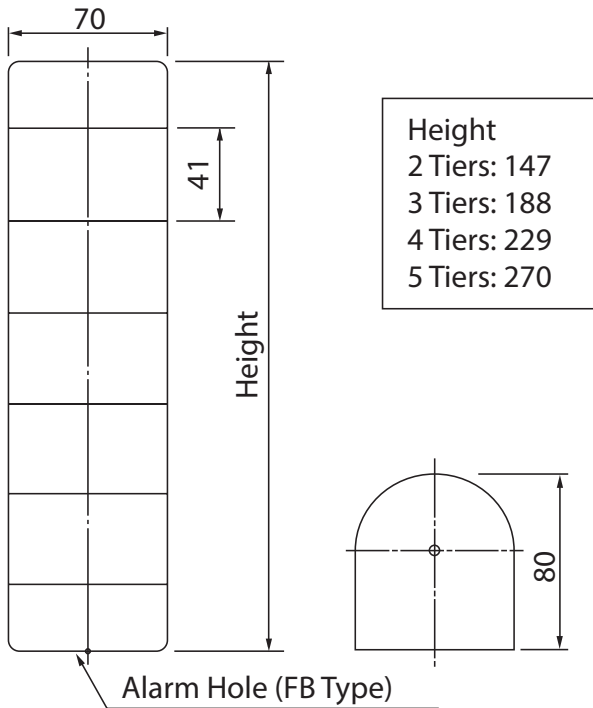

## Mounting Dimensions

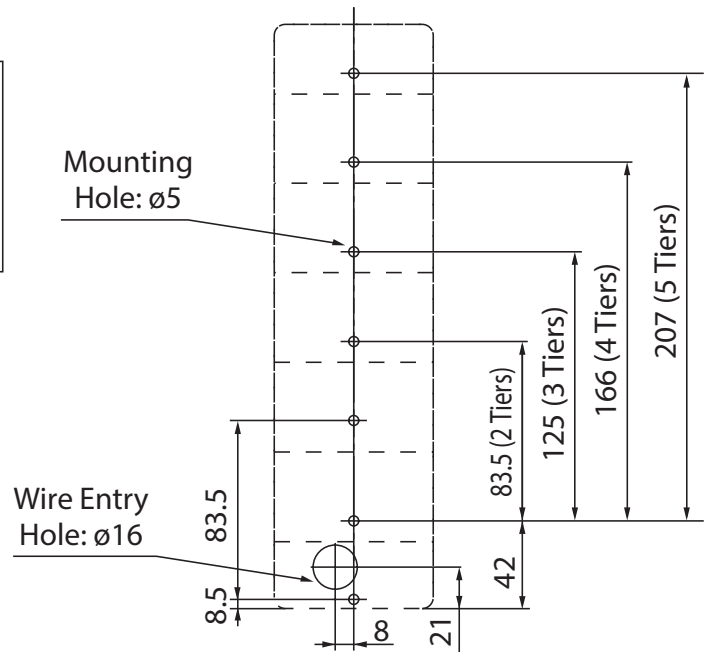

- The LED Colors are stackable, even after installation. However, the applicable Center Shaft and backplate needs to be purchased.
- Install with the alarm in the downward direction in order to preserve the IP54 rating.

Wiring

AC/DC 24V Lighting/Flashing Type

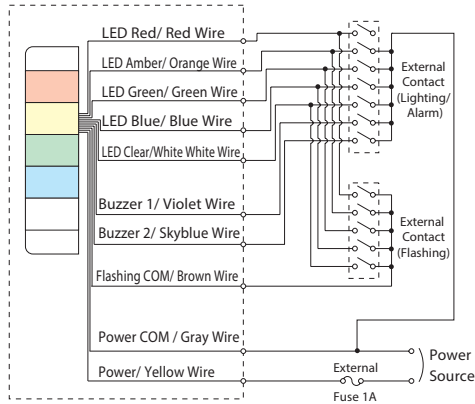

AC Power Lighting/Flashing Type

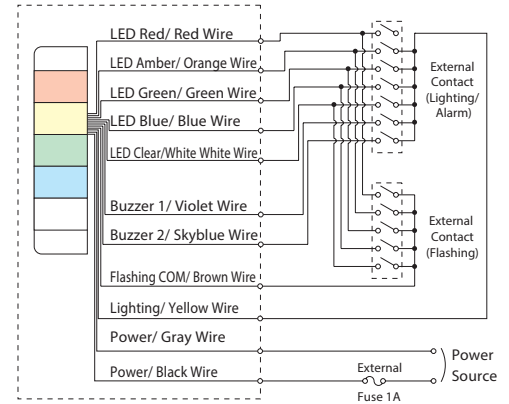

DC 24V NPN Type

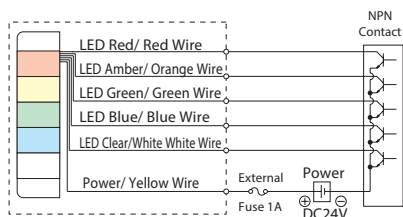

AC Power NPN Type

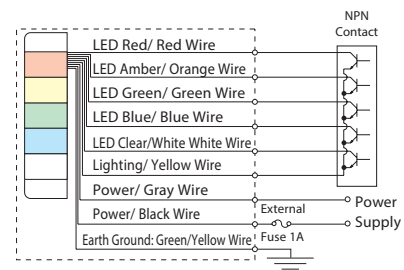

DC 24V NPN FB Type

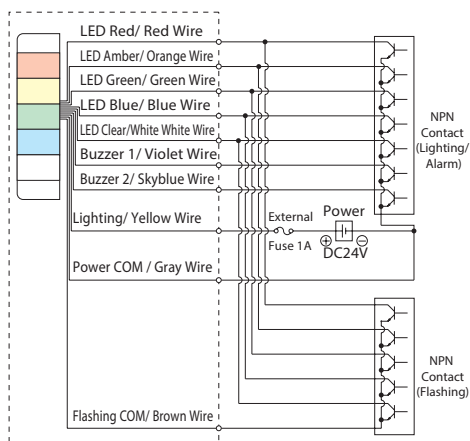

AC Power NPN FB Type

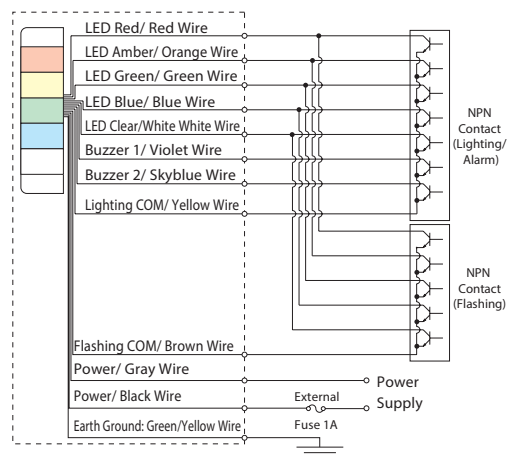

DC 24V PNP Type

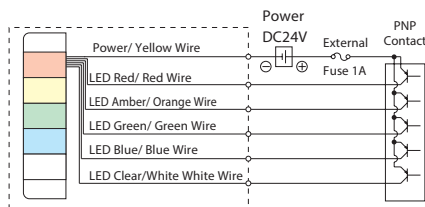

DC 24V PNP FB Type

