

## FIELDLED EVO 1040\_96 Aufbau, 1040 mm, 24V DC

**Artikel-Nr.:** 153310-01  
**EAN:** 4260556625539

**Bestell-Nr.:** 153310-01  
**Modell:** FIELDLED EVO 96 Aufbau  
**Bauform:** LED Aufbauleuchte für Maschinen  
**Leuchtmittel:** SMD LED  
**Lampenleistung:** ~78 W  
**Lampenlichtstrom:** 12000 lm  
**Lampenlichtausbeute:** 155 lm/W  
**Lichtverteilung:** direkt  
**Lichtfarbe:** Tageslichtweiß (5200 - 5700K)  
**Anschlusswert Leuchte:** 24V DC  $\pm$  10%  
**Anschluss Leuchte:** M12 Sensorstecker A-kodiert, stirnseitig  
**Schutzart:** IP67/IP69K  
**Schutzklasse:** III  
**Entblendung:** Mikroprismen  
**Abstrahlwinkel:** 100°  
**Betriebstemperatur:** -30... +60 °C  
**Farbwiedergabe (Ra):** > 85  
**Lampenlebensdauer:** > 60.000 h  
**Material Gehäuse:** Aluminium  
**Material Abdeckung:** ESG (Sicherheitsglas), splitterfrei  
**Höhe [B] x Breite [C]:** 30 x 96 mm  
**Länge [A]:** 1040 mm  
**Gewicht:** ~3450 g  
**Bruttogewicht:** ~4250 g  
**Risikogruppe:** freie Gruppe  
**Befestigungszubehör:** optional; 2 Schraubkanäle für M5 rückseitig  
**Dimmbar:** optional über Zubehör  
**Kennzeichnung:** CE, ETL Listed  
**Gefertigt in:** Deutschland

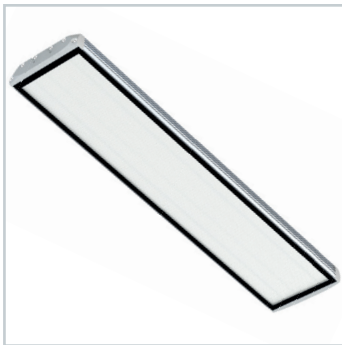

## FIELDLED EVO 1040\_96 Aufbau, 1040 mm, 24V DC

**Item number:** 153310-01  
**EAN:** 4260556625539

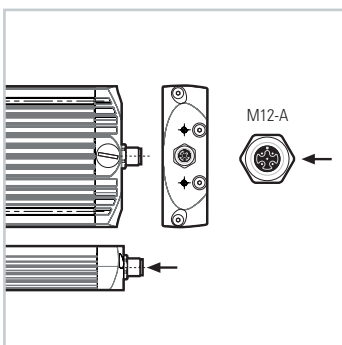
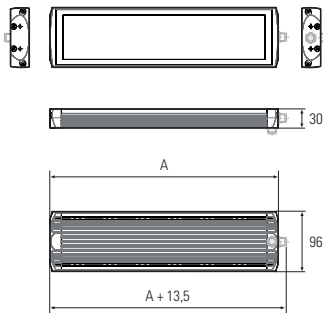
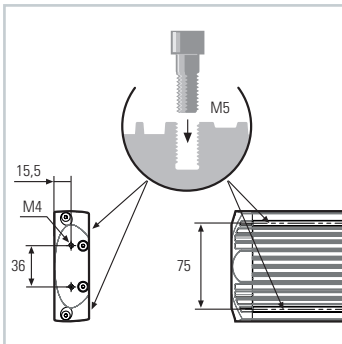

<b>Order number:</b>	153310-01
<b>Model:</b>	FIELDLED EVO 96 Aufbau
<b>Type:</b>	LED surface-mounted luminaire for machines
<b>Illuminant:</b>	SMD LED
<b>Power consumption:</b>	~78 W
<b>Lamp luminous flux:</b>	12000 lm
<b>Lamp luminous efficiency:</b>	155 lm/W
<b>Light distribution:</b>	direct
<b>Light colour:</b>	daylight white (5200 - 5700K)
<b>Connected load:</b>	24V DC $\pm$ 10%
<b>Connection:</b>	M12 sensor connector, A-type encoded, front-end
<b>Degree of protection:</b>	IP67/IP69K
<b>Class of protection:</b>	III
<b>Glare-free</b>	microprism
<b>Beam angle (optics):</b>	100°
<b>Operating temperature:</b>	-30... +60 °C
<b>Colour rendering (Ra):</b>	> 85
<b>Lamps lifetime:</b>	> 60,000 h
<b>Housing material:</b>	aluminium
<b>Cover material:</b>	ESG (toughened safety glass), shatterproof
<b>Height [B] x Width [C]:</b>	30 x 96 mm
<b>Length [A]:</b>	1040 mm
<b>Weight (net):</b>	~3450 g
<b>Gross weight:</b>	~4250 g
<b>Risk group (DIN EN 62471):</b>	free group
<b>Mounting accessories:</b>	optional; two continuous screw channels for metric screws with thread M5 on the reverse
<b>Dimmable:</b>	via optional accessory
<b>Marking:</b>	CE, ETL Listed
<b>Made in:</b>	Germany

Lamps lifetime in operation hours (L80/B10)

Irrtümer, Systemfehler und Änderungen vorbehalten.  
 Errors and technical changes excepted. 04.2022