

Do NOT scale the drawings. Instead rely on the dimensions and their definitions.
 SQ-MIM016920 1
 MARCHAND CLASS E IM1

Panasonic

Compact AC geared motor

Type : Electromagnetic Brake motor (Single phase)

UL, c-UL, CE, CCC approved

M9RZ60GR4GG1 4P 60W 220, 230V 50/60Hz

Capacitor: 5μF(450V)

Time rating: S2(cont.) Thermal Class: 130(B) IP44

Characteristics

Voltage	Frequency	rated current	rated input	rated speed	rated torque	starting torque	starting current	Brake input	Brake current	Holding brake torque
220V	50Hz	0.59A	126W	1300min ⁻¹	0.44N·m	0.56N·m	1.1A	10W	0.05A	0.39N·m
220V	60Hz	0.62A	133W	1600min ⁻¹	0.36N·m	0.57N·m	1.1A	10W	0.05A	0.39N·m
230V	50Hz	0.62A	135W	1300min ⁻¹	0.44N·m	0.62N·m	1.2A	10W	0.05A	0.39N·m
230V	60Hz	0.61A	139W	1625min ⁻¹	0.35N·m	0.62N·m	1.1A	10W	0.05A	0.39N·m

General Dimension Tolerance (±)										
Assembly					Dimension of A					
					Angle	(Shorter Side)				
Up to 6	Over 6 to 30	Over 30 to 120	Over 120 to 300	Over 300	Up to 10	Over 10 to 50	Over 50 to 100	Over 100 to 150	Over 150 to 300	45'
0.3	0.5	0.7	1.2	2.0	5'	3'	1.5'	1.5'	45'	

IP44: Applied when the direction of the lead wire hole (A) is downwards

Reduced drawing

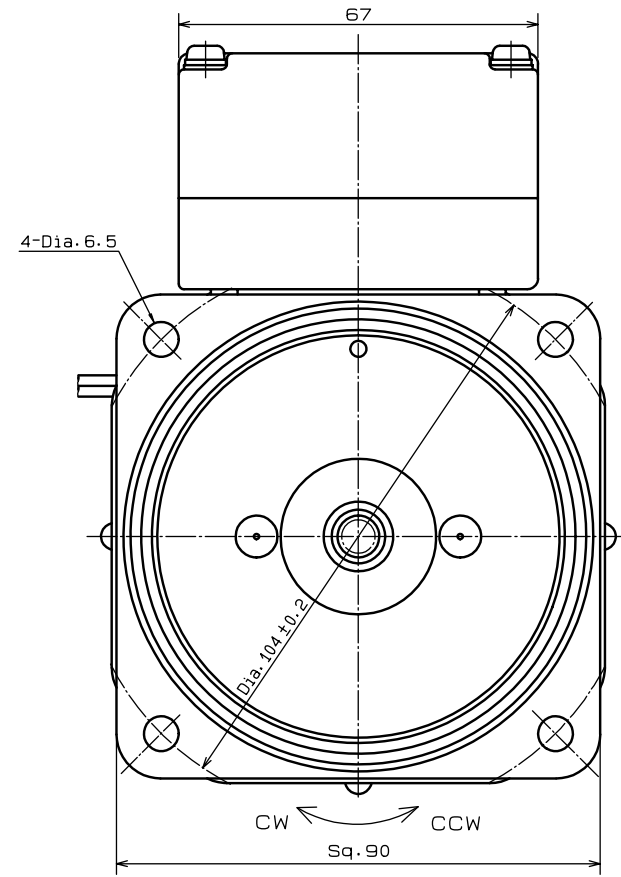
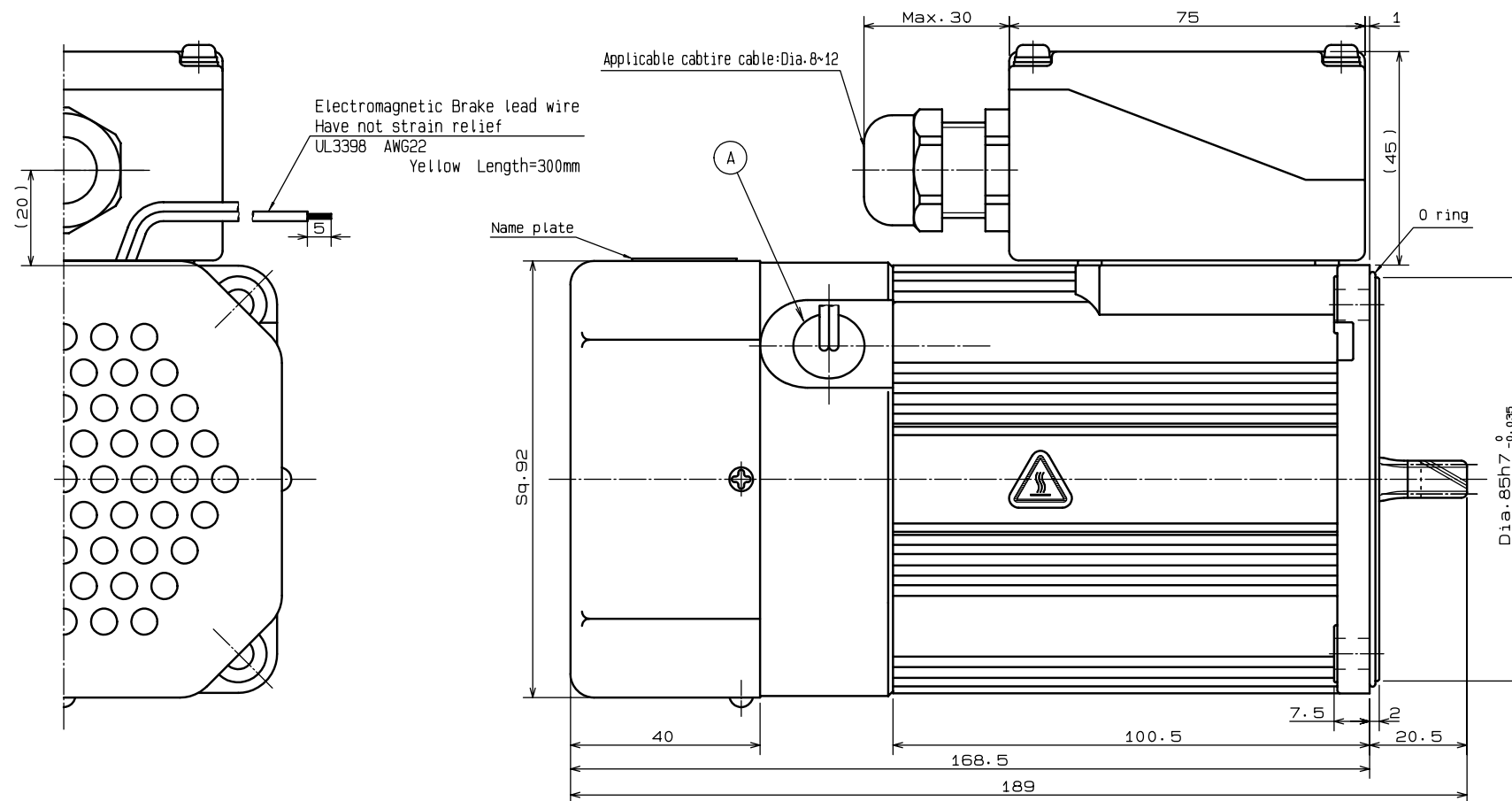

General specification

- Operational condition: ambient temperature -10°C~+40°C, the humidity: less than 85%RH.
- Shaft end edges assumes it less than 5/100(TIR).
- Please do not disassemble the motor. (It causes abnormal noise.)
- This motor has a thermal protector.
- Body color is dark brown.
- An electromagnetic brake operates by switching it off. It remove by switching on.
- A position of a switch please obey a connection diagram.
- Please use R1+C1 for protection between the point of contact of a switch. There is optional DV0P008. A commercial article: R1=10~200μ, More than 1/4W, C1=0.1~0.33μF, More than 250V.
- As for the life of this motor, an electromagnetic brake is 1,000,000 times at permission inertia in 0.875kg·cm².
- Applicable gear head: MZ9GDB (ball bearing hinge nothing), MY9GDB (ball bearing hinge existence), MR9GDB (ball bearing hinge nothing), MP9GDB (ball bearing hinge existence)
- Applicable decimal gear head: MZ9G10XB.
- When put a gear head together, please confirm that an O ring attached to a motor. (If there is not an O ring, it cause an oil blur.)
- Perform connection of terminals of a capacitor surely. Do the electric insulation so that electricity department of a capacitor does not crop out.
- Accessory: Capacitor

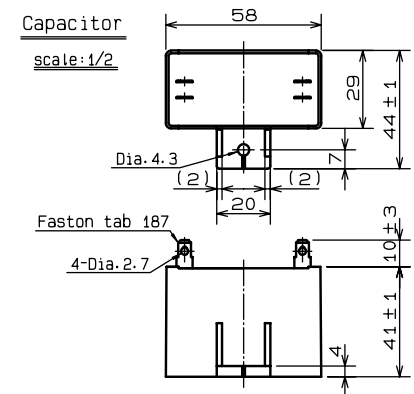
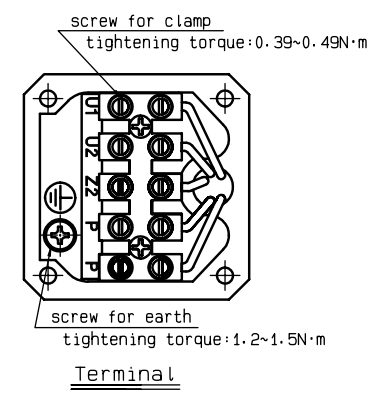
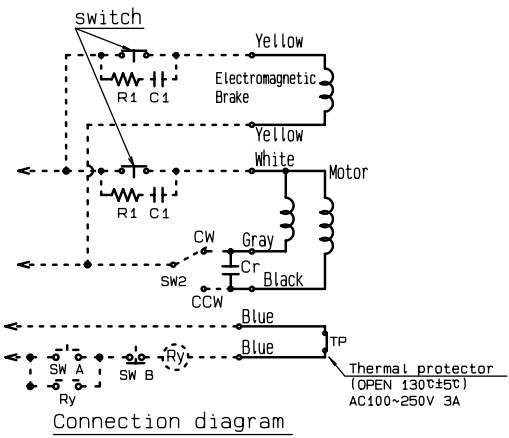

Scale	MATSUSHITA ELECTRIC INDUSTRIAL CO., LTD.	Agreement	Model
1 : 1	3rd Angle System Unit: mm		M9RZ60GR4GG1
Designed	Drawn	Checked	Name
KITAMURA	KITAMURA	WADA	OUTLINE DRAWING
2007/02/09	2007/02/09	2007/02/09	No.
			SQ-MIM0169201