

SQ-MIM0127101

Do NOT scale the drawings. Instead, rely on the dimensions and their definitions.

Panasonic

Compact AC geared motor
 Type: Induction motor
 UL, c-UL, CE, CCC approved
 M91Z60GK4GGA 4P 60W 220-230V 50/60Hz
 Capacitor: 4.5μF(450V)
 Time rating: S1(cont.) Thermal Class: 130(B) IP54

Characteristics							
Voltage	Frequency	rated current	rated input	rated speed	rated torque	starting torque	starting current
220V	50Hz	0.58A	121W	1275min ⁻¹	0.45N·m	0.49N·m	1.1A
220V	60Hz	0.55A	120W	1600min ⁻¹	0.36N·m	0.49N·m	1.1A
230V	50Hz	0.61A	129W	1300min ⁻¹	0.44N·m	0.53N·m	1.1A
230V	60Hz	0.55A	126W	1625min ⁻¹	0.35N·m	0.53N·m	1.1A

General Dimension Tolerance (+)									
Assembly					Angle				
					Dimension of A				
					(Shorter Side)				
Up to 6	Over 6 to 30	Over 30 to 120	Over 120 to 300	Over 300	Up to 10	Over 10 to 50	Over 50 to 100	Over 100	Over 100
0.3	0.5	0.7	1.2	2.0	5°	3°	1.5°	45°	

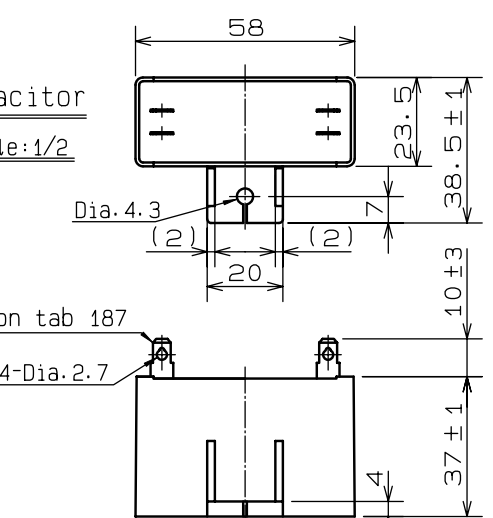
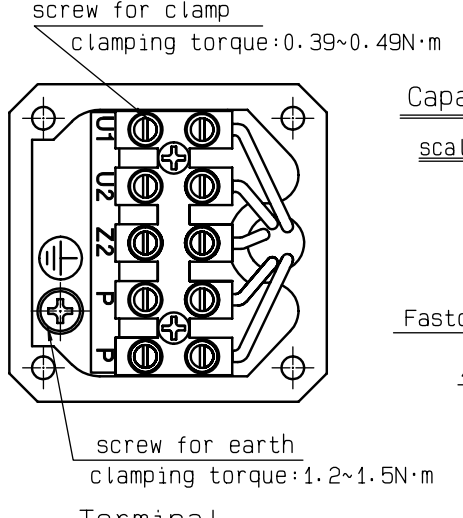
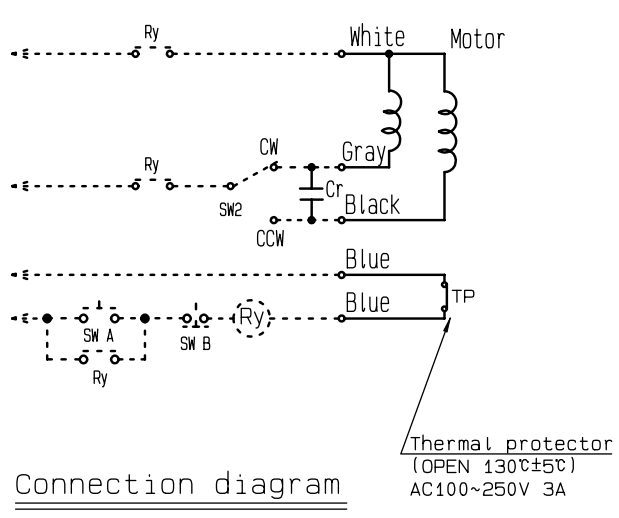
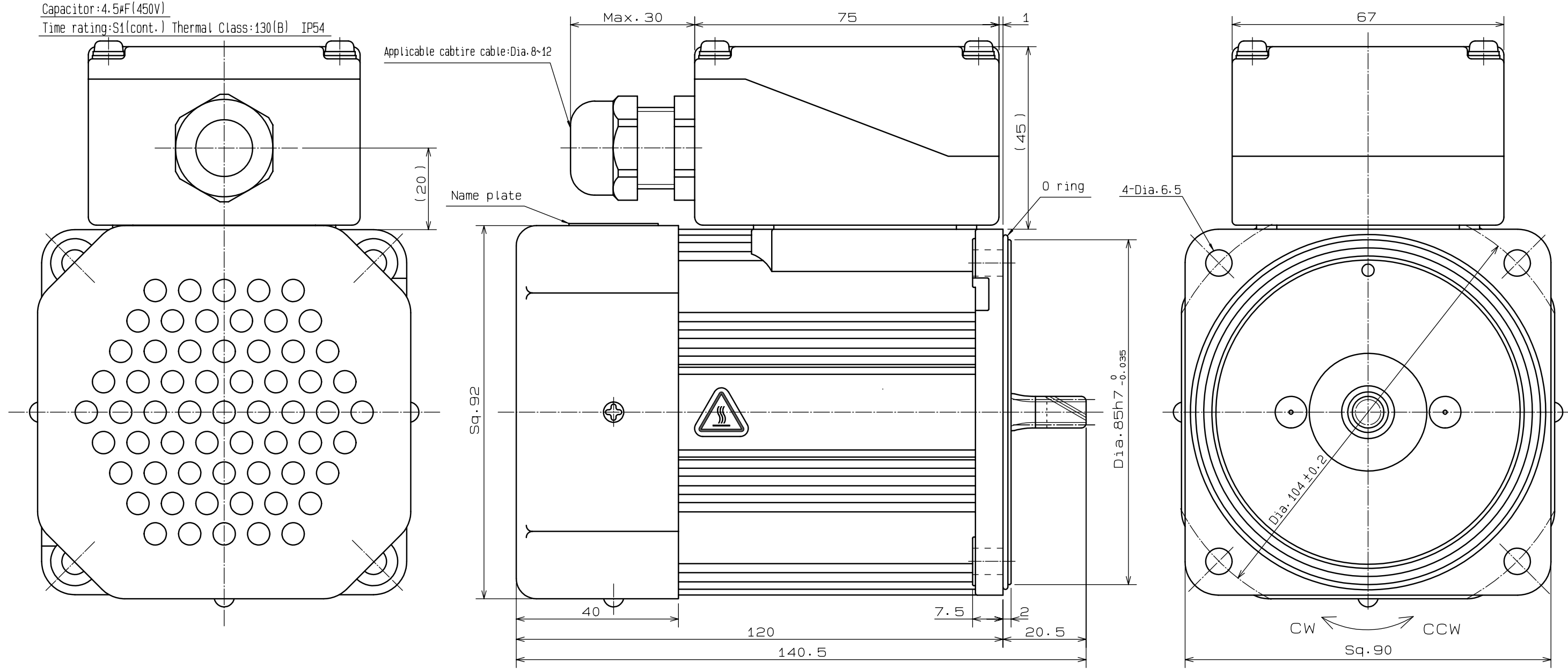

General specification

- Perform connection of terminals of a capacitor surely. Do the electric insulation so that electricity department of a capacitor does not crop out.
- Operational condition: ambient temperature -10°C~+40°C, the humidity: less than 85%RH.
- Shaft end edges assumes it less than 5/100(TIR).
- Please do not disassemble the motor. (It causes a peculiar noise.)
- This motor has a thermal protector.
- Body color is dark brown.
- Application gear heads: MZ9G0B (a ball bearing hinge nothing)
 MY9G0B (a ball bearing hinge existence)
 MR9G0B (a ball bearing hinge nothing)
 MP9G0B (a ball bearing hinge existence)
- Application decimal gear heads: MZ9G10XB
- When put a gear head together, please confirm that an O ring attached to a motor. (If there is not an O ring it cause an oil blur.)
- Accessories: Capacitor

Scale	MATSUSHITA ELECTRIC INDUSTRIAL CO.,LTD.	Agreement	Model	M91Z60GK4GGA
1 : 1	3rd Angle System	Unit:mm	Name	OUTLINE DRAWING
Designed	Drawn	Checked	Checked	Checked
ITO	ITO	SHIMIZU	KITAMURA	
2006/10/27	2006/10/27	2006/10/31	2006/10/31	No.
				SQ-MIM0127101

MARCHAND CLASS IM1 E