

SQ-DIMA72801

Panasonic

AC gear motor
<G series>

Type : Decimal Gearhead
Model : MZ9G10XB

Assembly					General Dimension Tolerance (±)			
					Angle		Dimension of A	
							(Shorter Side)	
Up to 6	Over 6 to 30	Over 30 to 120	Over 120 to 300	Over 300	Up to 10	Over 10 to 50	Over 50 to 100	Over 100
0.3	0.5	0.7	1.2	2.0	5°	3°	1.5°	45°

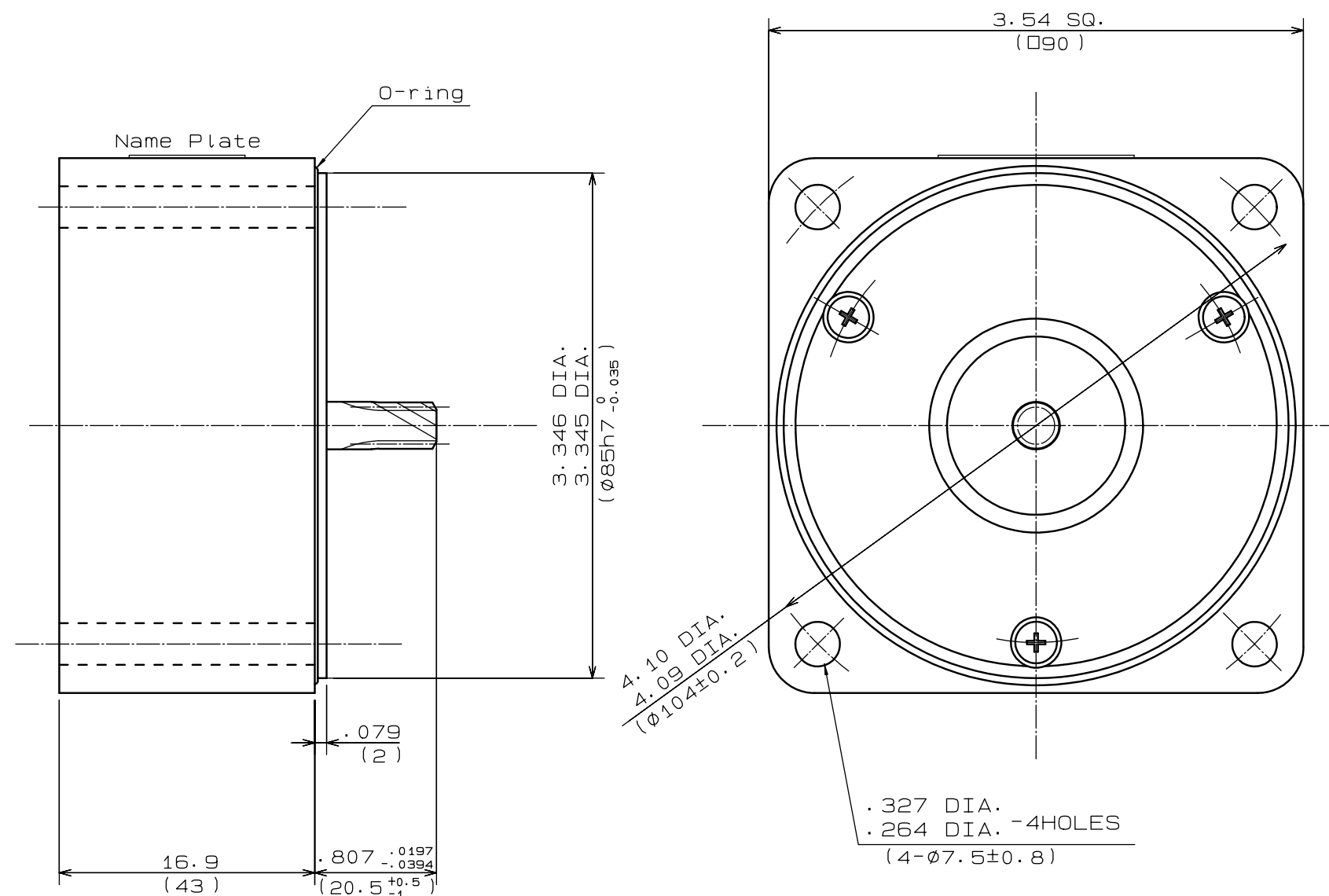

General specification

- Color : Standard Color (Dark brown)
- Ambient temperature : -10°C~+40°C
- Ambient humidity : Less than 85%RH
- Nominal gear reduction ratio is "1:10"
Actual gear reduction ratio is "1:9.97"
- The rotating direction of output shaft is as same as the rotating direction of motor-shaft.
- Please make sure the O-ring (for oil seal) is set up in the properly position of the motor-bracket when you assemble the motor and the gear head.
- Without Accessories.
Fixing bolts (Hexagon socket head cap screw) which are used to assemble the motor and the gear-head are prepared as an option-parts.

FOR MZ9G□B : M6 length 4.92in(125mm)
4Pieces

FOR MY9G□B : M6 length 2.56in(65mm)
4Pieces

MARCHAND CLASS IM1 J OGAWA TRACE OGAWA 14.May.2001

Scale	MATSUSHITA ELECTRIC INDUSTRIAL CO.,LTD.			Agreement	Model	MZ9G10XB
1 : 1	3rd Angle System		Unit:in(mm)			Name
Designed	Drawn	Checked	Checked	Approved	No.	
OGAWA	OGAWA		YAMAGUCHI	KOMINE		
14.May.2001	14.May.2001		14.May.2001	14.May.2001		