

SQ-MIMO 119302

Do NOT scale the drawings, instead rely on the dimensions and their definitions

Panasonic

Model: MP9G50B~MP9G200B Bearing type: Ball bearing

Compact AC geared motor

Type : Gear head

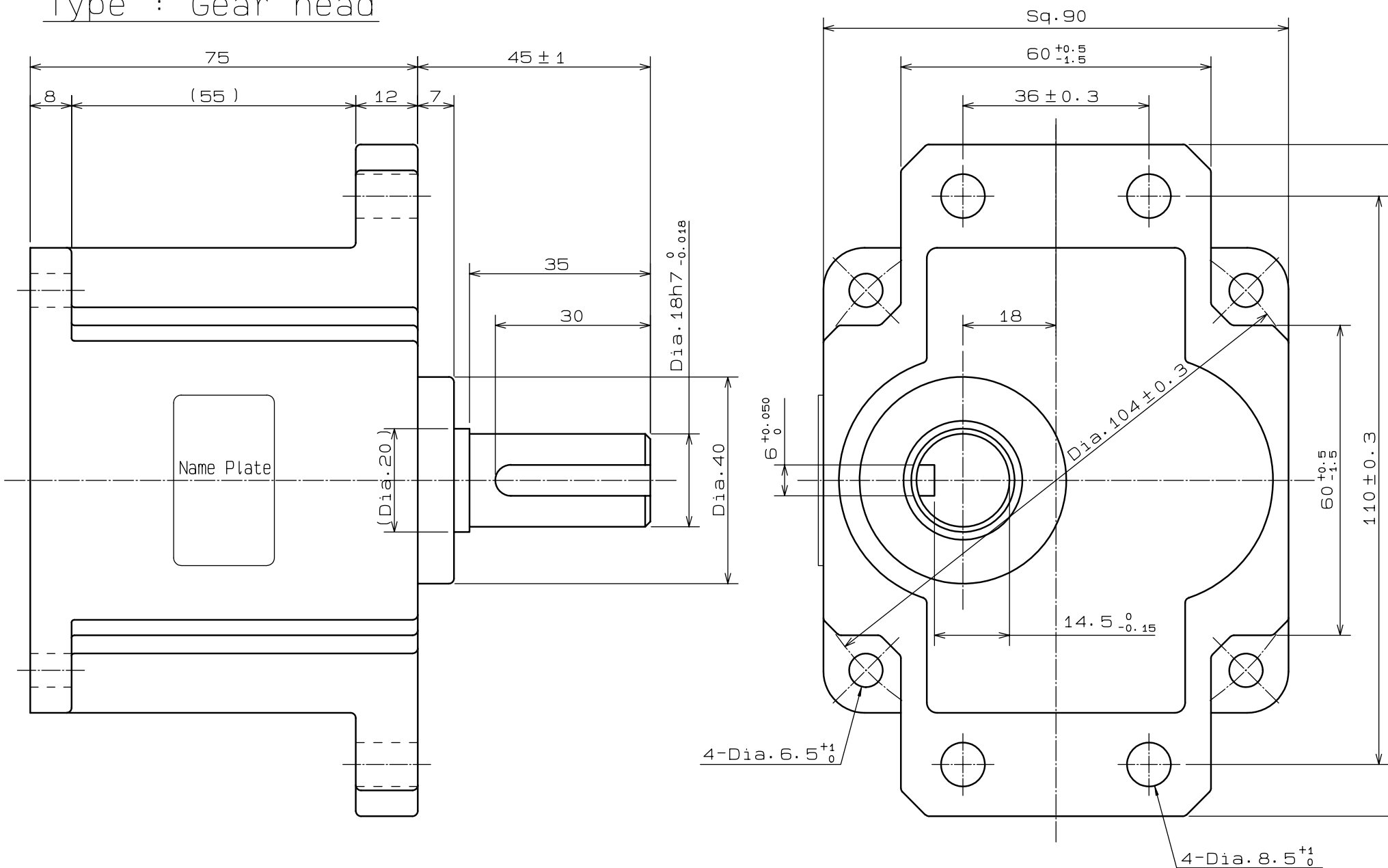

Geared motor maximum permissible torque table

Model		MP9G 50B	MP9G 60B	MP9G 75B	MP9G 90B	MP9G 100B	MP9G 120B	MP9G 150B	MP9G 180B	MP9G 200B
Nominal gear reduction ratio		50	60	75	90	100	120	150	180	200
Actual gear reduction ratio		50.9	60.5	76.0	89.8	98.6	121.2	150.4	182.1	202.1
Speed (min ⁻¹)	50Hz	30	25	20	16.7	15	12.5	10	8.3	7.5
	60Hz	36	30	24	20	18	15	12	10	9
Permissible torque (N·m)	Motor Output 60W	50Hz	15.2	18.2	22.1	26.5	29.4			
		60Hz	12.7	15.2	18.6	22.1	24.6	29.4		
	Motor Output 90W	50Hz	21.2	25.5	29.4					
		60Hz	17.6	21.2	26.7	29.4				
Direction of rotation of Output shaft		The same direction as the shaft of the motor								

Scale	MATSUSHITA ELECTRIC INDUSTRIAL CO.		
1 : 1	3rd Angle System Un		
Designed	Drawn	Checked	Chec
WADA	WADA		
2006/11/09	2006/11/09		

MARCHAND CLASS J IM1 TRACE